

# Intermittent Bagmaker S650



The S650 excels at bulk bag packaging! We offer all types of fillers, full surround mezzanines, bag compression units, and automatic pallet-packing equipment for bulk bags of powders, wood chips, soil, grains, and more.

max.  
speed

50  
bpm

bag  
size

max.  
650 mm × 1 000 mm (25.6" × 39.37")  
min.  
250 mm × 150 mm (9.84" × 6")

## Bag Types

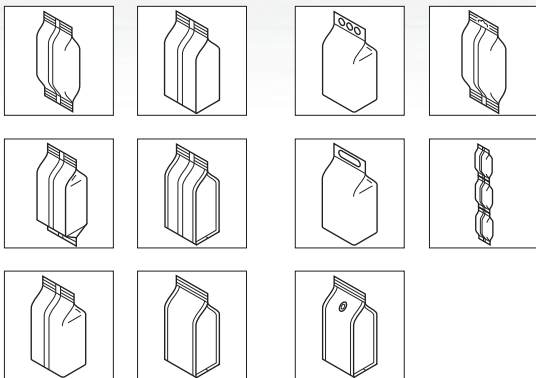

## Bag Options

## Recloseable Solutions

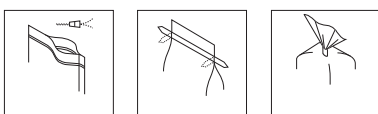

# Intermittent Bagmaker S650 In Detail

Save with automation. Save with improved palletization. Save with this heavyweight champion that packs efficiency and cost-savings into one reliable machine. The S650 bagger is engineered to streamline the form, fill and seal process and churn out large bags that stack cleanly and easily onto pallets. Plus, with rollstock, sewed bags are a distant memory. Clumsy hand-sealed bags. Inconsistent pallet stacks. All a thing of the past with the fully adaptable S650. Your wallet and reputation will benefit.

## features

- > Robust, stainless steel frame
- > Siemens or Allen Bradley control system
- > Enclosed, servo-drive jaw actuation
- > Quiet running speeds up to 50 cycles per minute
- > Off-the-shelf components
- > Minimal maintenance requirements
- > Short film path
- > No tool change-over
- > Self-centering pull belts
- > Automatic film tracking
- > VFD powered film unwind
- > Quick film splice table
- > Photo eye and encoder
- > Jaw obstruction detection
- > Film reel lifting unit
- > Runs most film structures
- > Storage for 100 product recipes

## options

- > Quad seal bag assembly
- > Flat bottom bag assembly
- > Impulse sealing for poly film structures
- > Washdown IP66 construction
- > Atex explosion-proof construction
- > Vacuum pull belts
- > Hole punch (Euroslot and Round)
- > Load shelf
- > Product settler
- > Gas flush
- > Static elimination
- > Tear notch
- > Product stagers
- > End-seal cooling air
- > Bag deflators
- > Degassing valve applicator
- > Remote diagnostics
- > Zipper applicator
- > Integration with variety of fillers, printers, metal detectors, label applicators, and checkweighers
- > In-feed and take-away conveyors

**Max. speed**  
50 bpm

**Weight**  
1 600 kg (3,525 lbs)

**Bag width**  
250–650 mm  
(9.84"–25.6")

**Air pressure**  
6 bar  
(16–25 CFM at 90 PSI)

**Bag length**  
150–1 000 mm  
(6"–39.37")

**Power supply**  
16.5 kVA  
(480 V, three phase,  
50/60 Hz., 20 AMPS)



## Machine drawings

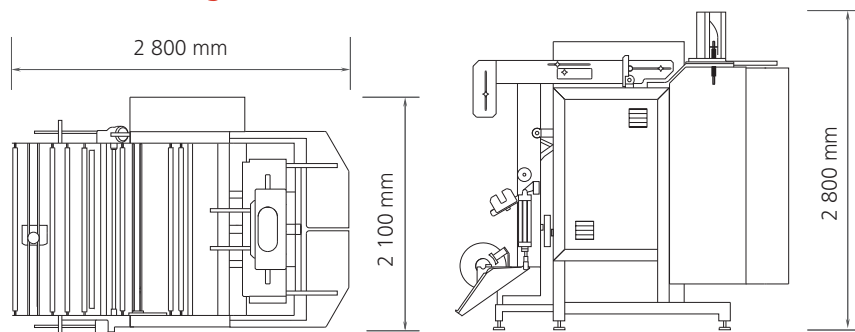

### Europe, Asia, Africa, Australia

Viking Mašek, a.s. | Průmyslová 1747 | 258 01 Vlašim | Czech Republic

**Phone** +420 317 850 500 | **Email** info@masek.cz | **Website** www.masek.cz, www.vikingmasek.cz

### North and South America

Viking Masek Global Packaging Technologies, Inc. | 40 Woodland Court | Oostburg, WI 53070 | USA

**Phone** +1 920 564 5051 | **Email** sales@vikingmasek.com | **Website** www.vikingmasek.com